

Bolt Preload Force Sensor

K119



◆ 特点与用途/Features & Applications

- 外形尺寸小
- 不锈钢/合金钢材料
- 螺纹力的监测
- 汽车压装、自动化组装、3C产品测试、新能源产品组装、医疗检测、机器人领域，模具组装及其他工业测试、测量及控制系统

- Low profile, small deflection
- Made of stainless steel or Alloy steel
- Mainly used for monitoring of thread force
- Suitable for Automotive press fit, automated assembly, 3CS products testing, new energy product assembly, medical testing, robotics, mold assembly and other industrial testing and controlling system

◆ 参数 Specifications 技术指标/Technique

参数	Specifications	技术指标/Technique
额定容量	Capacity	10,20,30,50,100,200kN
输出灵敏度	Sensitivity	1.5 ± 10% mV/V
零点输出	Zero balance	± 0.03 mV/V
非线性	Non-linearity	0.1% F.S.
滞后	Hysteresis	0.1% F.S.
重复性	Repeatability	0.05% F.S.
蠕变 (30min)	Creep(30min)	0.05% F.S.
温度灵敏度漂移	Temp.effect on output	0.05% F.S./10°C
零点温度漂移	Temp.effect on zero	0.05% F.S./10°C
输入电阻	Input impedance	780 ± 20 Ω
输出电阻	Output impedance	700 ± 10 Ω
绝缘电阻	Insulation	≥ 5000MΩ/100VDC
激励电压	Recommended excitation	5-15V
最大激励电压	Maximum excitation Voltage	20V
温度补偿范围	Compensated temp range	-10-60°C
工作温度范围	Operating temperature range	-20-80°C
安全载荷	Safe load limit	150% F.S.
破坏负载	Breaking load	200% F.S.
电缆线尺寸	Cable size	φ 4 × 4000mm
防护等级	IP Class	IP67

◆ 安装尺寸/Mounting Dimension

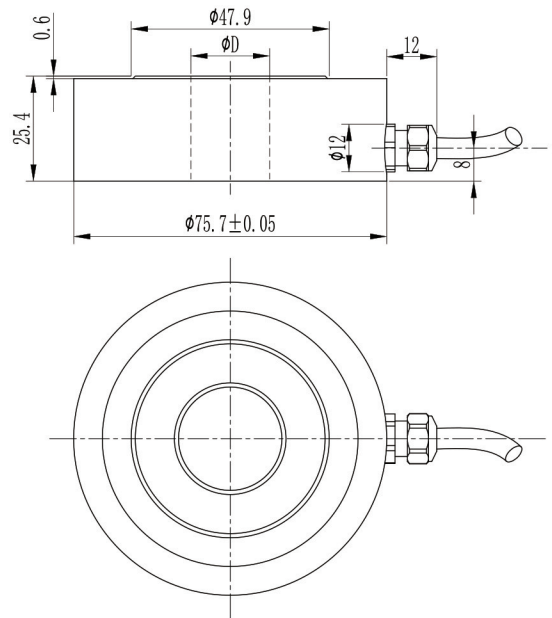

Capacity (kN)	10,20,30,50,100,200
ΦD(mm)	7,9,11,15,17,19,21,25,32

注：内孔和量程可自由匹配
Note: The hole and range can be freely matched.

◆ 受力方式/Load Direction

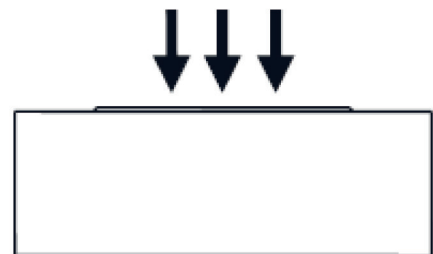

◆ 配线图/Wiring Code

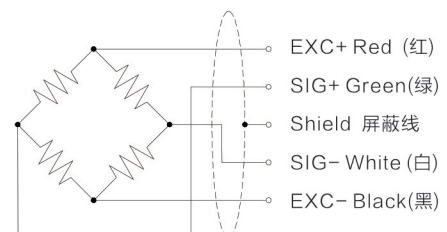

新产品

压向传感器

拉压向传感器

压电力传感器

多维力传感器

称重传感器

张力传感器

螺纹力

扭矩传感器

其它定制力传感器

称重模块

仪表模块放大器