

K120



◆ 特点与用途/Features & Applications

- 高度低，变形量小，外形尺寸小
 - 不锈钢材料，精度高
 - 防护等级：IP68，防护等级高，可用于室外或恶劣环境
 - 汽车压装、自动化组装、3C产品测试、新能源产品组装、医疗检测、机器人领域，模具组装及其他工业测试、测量及控制系统
 - 动态响应频率高
- Low profile, small deflection and mini dimension
 - Made of stainless steel with high accuracy
 - IP68 protection, good protection would be used for outdoor or harsh environments
 - Suitable for Automotive press fit, automated assembly, 3C products testing, new energy product assembly, medical testing, robotics, mold assembly and other industrial testing and control system
 - High dynamic response frequency

◆ 安装尺寸/Mounting Dimension

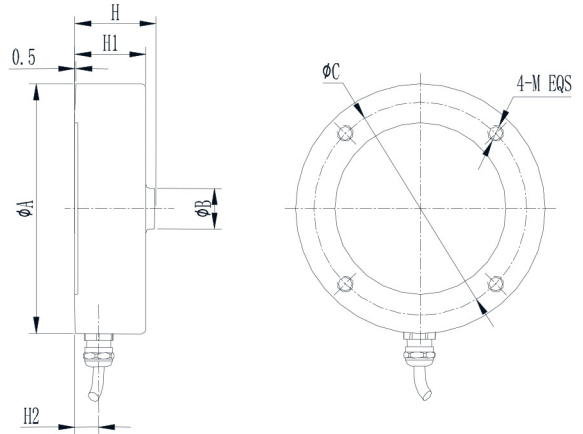

Cap (kN)	A	B	C	H	H1	H2	M
25	65	10	54.2	25	21	10	M5deep8
50	110	20	95	35	30	14	M6deep12
100	125	20	105	40	35	14	M6deep12
250	135	32	115	60	50	14	M12deep20
500	175	45	145	65	53	14	M12deep20

◆ 参数 Specifications 技术指标/Technique

额定容量	Capacity	25, 50,100,250, 500kN
输出灵敏度	Sensitivity	2.0 ± 1% mV/V
零点输出	Zero balance	± 0.05 mV/V
非线性	Non-linearity	0.05%F.S.
滞后	Hysteresis	0.03%F.S.
重复性	Repeatability	0.02%F.S.
蠕变 (30min)	Creep(30min)	0.02%F.S.
温度灵敏度漂移	Temp.effect on output	0.03%F.S./10°C
零点温度漂移	Temp.effect on zero	0.03%F.S./10°C
输入电阻	Input impedance	385/780 ± 20 Ω
输出电阻	Output impedance	350/700 ± 10 Ω
绝缘电阻	Insulation	≥ 5000MΩ/100VDC
激励电压	Recommended excitation	5-15V
最大激励电压	Maximum excitation Voltage	20V
温度补偿范围	Compensated temp range	-10-60°C
工作温度范围	Operating temperature range	-20-80°C
安全载荷	Safe load limit	150%F.S.
破坏载荷	Breaking load	200%F.S.
电缆线尺寸	Cable size	φ 5 × 5m (25-100kN) φ 5 × 10m (250-500kN)
材料	Material	Stainless Steel (不锈钢)
防护等级	IP Class	IP68

◆ 受力方式/Load Direction

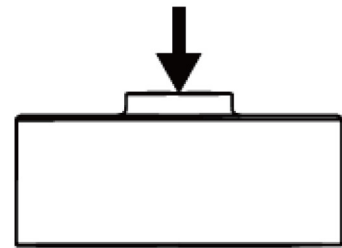

◆ 配线图/ Wiring Code

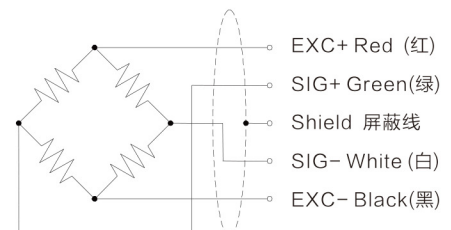

新产品

压向传感器

拉压向传感器

压电力传感器

多维力传感器

称重传感器

张力传感器

螺紋力

扭矩传感器

其它定制力传感器

称重模块

仪表模块放大器