

K197

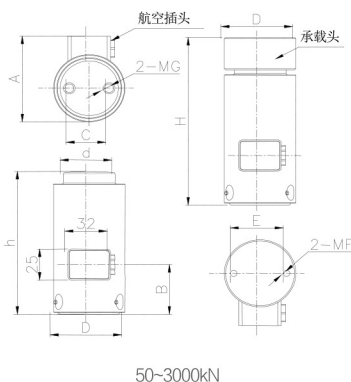

50-3000kN

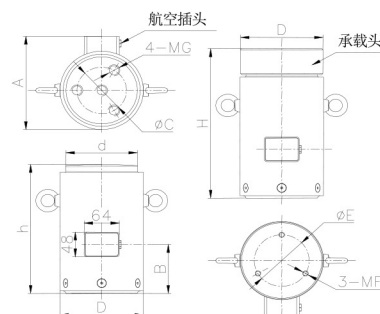

5000-50000kN

Cap (kN)	A	B	C	D	d	E	H	h	F	G
50,100,200,500	74	42	30	54	39	40	135	115	M6深10	M8深12
1000	98	55	40	78	56	50	175	150	M6深10	M12深20
2000	128	65	60	103	84	75	245	210	M10深16	M16深25
3000	155	85	75	125	102	90	290	250	M10深16	M16深25
5000	182	95	90	152	126	100	370	330	M10深16	M20深30
10000	245	105	120	215	190	120	445	400	M10深16	M20深30
20000	330	150	200	295	260	200	650	570	M12深20	M24深40
50000	487	185	300	455	420	300	800	600	M12深20	M24深40

参数 Specifications 技术指标/Technique

额定容量	Capacity	50,100,200,500,1000,2000,3000 5000,10000,20000,50000kN
输出灵敏度	Rated output	~2.0mV/V
零点输出	Zero balance	± 1%F.S.
非线性	Non-linearity	0.02%,0.05%,0.1%,0.3% F.S.
滞后	Hysteresis	0.02%,0.05%,0.1%,0.3% F.S.
重复性	Repeatability	0.02%,0.05%,0.1%,0.3% F.S.
蠕变 (30min)	Creep(300min)	0.02%,0.05%,0.1%,0.3% F.S.
温度灵敏度漂移	Temp.effect on output	0.05%F.S./10℃
零点温度漂移	Temp.effect on zero	0.05%F.S./10℃
输入电阻	Input impedance	760 ± 20Ω
输出电阻	Output impedance	700 ± 10Ω
绝缘电阻	Insulation	≥5000MΩ/100VDC
激励电压	Recommended excitation	5V
最大激励电压	Maximum excitation	15V
温度补偿范围	Compensated temp range	-10~60℃
工作温度范围	Operation temp range	-30~70℃
安全超载	Safe overload	150%F.S.
极限超载	Ultimate overload	300%F.S.
电缆线尺寸	Cable size	φ 5.4 × 6000mm
材料	Material	Stainless Steel / Alloy Steel (不锈钢 / 合金钢)
防护等级	IP class	IP67

安装尺寸/Mounting Dimension

特点与用途/Features & Applications

- 稳定性强
 - 适用于各种环境，防护等级 IP67
 - 最大容量高达 5000t
 - 主要应用于测力设备
 - 可作为计量用的测量标准源
- Strong stability
 - Used in various automated stamping applications, IP67 protection
 - Max capacity up 5000 ton
 - Mainly used in force measurement device
 - Can be used as a measurement standard for measurement

受力方式/Load Direction

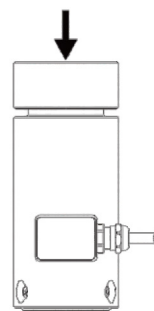

配线图/Wiring Code

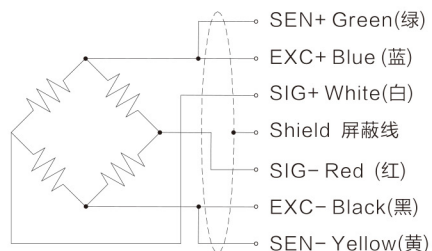

新产品

压向传感器

拉压向传感器

压电力传感器

多维力传感器

称重传感器

张力传感器

螺纹力

扭矩传感器

其它定制力传感器

称重模块

仪表模块放大器