

K550

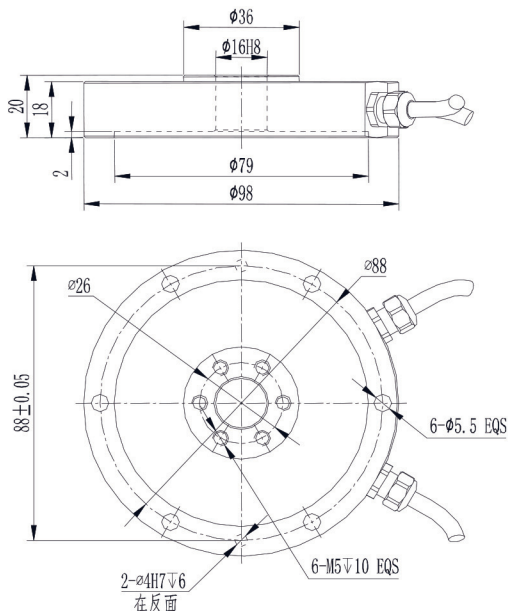

◆ 安装尺寸/Mounting Dimension



◆ 特点与用途/Features & Applications

- 压扭复合力传感器
- 两信号互扰误差小
- 高度低，易于安装
- 接受定制规格
- 应用于汽车压装、自动化组装、3C产品测试、新能源产品组装、医疗检测、机器人领域，模具组装及其他工业测试、测量及控制系统
- Compression & Torque Biaxial Sensor
- Interference errors of each signal is small
- Low profile, easy to install
- Dimension could be Customized
- Used for automotive press fit, automated assembly, 3C products testing, new energy product assembly, medical testing, robotics, mold assembly and other industrial testing and control system

◆ 参数 Specifications 技术指标/Technique

参数	Specifications	技术指标/Technique
额定容量	Capacity (N/N.m)	F: 20/30/50/100/200/500/1000/2000N M: 1/2/3/5/10/20/30/50N.m
输出灵敏度	Sensitivity	1.0 ± 10% mV/V
零点输出	Zero balance	± 2% F.S.
非线性	Non-linearity	0.1% F.S.
滞后	Hysteresis	0.1% F.S.
重复性	Repeatability	0.1% F.S.
互扰误差	Interference error	0.2% F.S.
蠕变 (30min)	Creep(30min)	0.05% F.S.
温度灵敏度漂移	Temp.effect on output	0.05% F.S./10°C
零点温度漂移	Temp.effect on zero	0.05% F.S./10°C
输入电阻	Input impedance	350 ± 10 Ω
输出电阻	Output impedance	350 ± 10 Ω
绝缘电阻	Insulation	≥ 5000M Ω/100VDC
激励电压	Recommended excitation	5~15V
最大激励电压	Maximum excitation Voltage	20V
温度补偿范围	Compensated temp range	-10~40°C
工作温度范围	Operating temperature range	-20~75°C
安全载荷	Safe load limit	150% F.S.
破坏负载	Breaking load	200% F.S.
电缆线尺寸	Cable size	Φ4 × 4000mm
单件重量	Weight approx.	0.6kg
防护等级	IP Class	IP66

◆ 受力方式/Load Direction

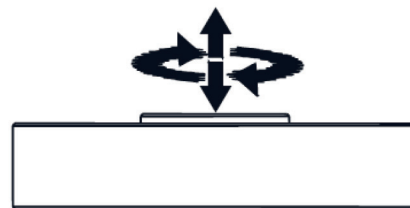

◆ 配线图/ Wiring Code

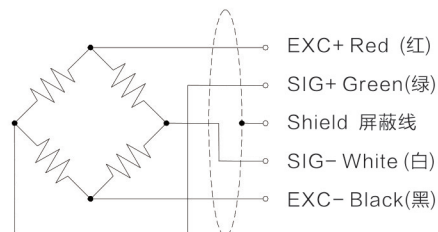

新产品

压向传感器

拉压向传感器

压电力传感器

多维力传感器

称重传感器

张力传感器

螺纹力

扭矩传感器

其它定制力传感器

称重模块

仪表模块放大器