

K908A

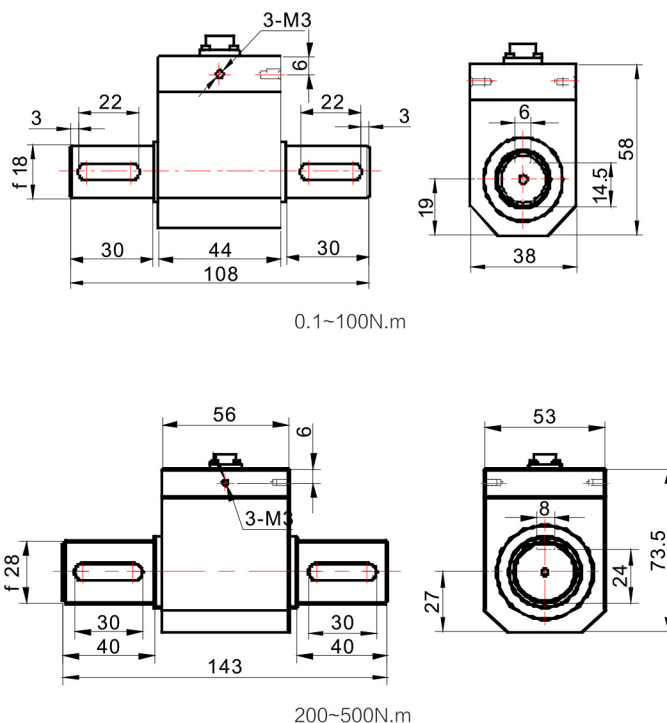

◆ 安装尺寸/Mounting Dimension



◆ 参数 Specifications 技术指标/Technique

参数	Specifications	技术指标/Technique
额定容量	Capacity	0.1,0.2,0.3,0.5,1,2,3,5,10,20 30,50,100,200,300,500N.m
输出灵敏度	Sensitivity	1.0~1.5mV/V
零点输出	Zero balance	±1% F.S.
非线性	Non-linearity	0.2%F.S.
滞后	Hysteresis	0.2%F.S.
重复性	Repeatability	0.1%F.S.
蠕变 (30min)	Creep(30min)	0.1%F.S.
温度灵敏度漂移	Temp.effect on sensitivity	0.02%F.S./10°C
零点温度漂移	Temp.effect on zero	0.02%F.S./10°C
输入电阻	Input impedance	350/700 ± 10 Ω
输出电阻	Output impedance	350/700 ± 10 Ω
绝缘电阻	Insulation	≥2000M Ω/100VDC
激励电压	Recommended excitation	12V
最大激励电压	Maximum excitation Voltage	15V
温度补偿范围	Compensated temp range	-10~60°C
工作温度范围	Operating temperature range	-20~60°C
安全载荷	Safe load limit	120%F.S.
破坏负载	Breaking load	150%F.S.
电缆线尺寸	Cable size	3m
防护等级	IP Class	IP66

◆ 特点与用途/Features & Applications

- 电阻应变为敏感元件和集成电路构成的一体产品;
 - 精度高, 性能稳定可靠;
 - 没有集流环等磨损件, 可高速长时间运转, 输出正反扭矩信号;
 - 两端均为键连接;
 - 最高转速不超过4000转/分钟。
- Constituted by Strain gauge sensitive components and integrated circuits;
 - High precision with stable and reliable performance;
 - This sensor can be operated long-term in high-speed without wear ring and other wear parts, the output is OK for positive and negative torque signal;
 - Both ends are keyed;
 - Maximum speed of torque cannot over 4000 r / min.

◆ 配线图/Wiring Code

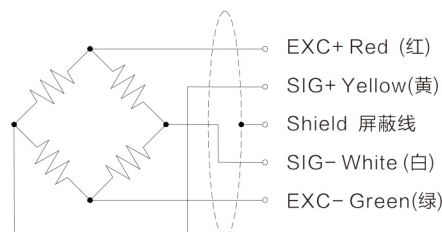

新产品

压向传感器

拉压向传感器

压电力传感器

多维力传感器

称重传感器

张力传感器

螺纹力

扭矩传感器

其它定制力传感器

称重模块

仪表模块放大器